

THIS COPY IS PROVIDED ON A RESTRICTED BASIS AND IS NOT TO BE USED IN ANY WAY DETRIMENTAL TO THE INTERESTS OF PANDUIT CORP.

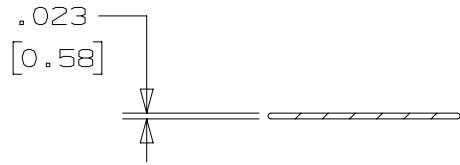

SECTION A - A
SCALE 2:1

PART NO.	MAX. BUNDLE DIA [mm]	LENGTH L ± .1 (mm)
MSC4W50T15-L6	4" [102]	18.0" [457]
MSC6W50T15-L6	6" [152]	24.4" [620]
MSC8W50T15-L6	8" [203]	30.7" [780]
MSC10W50T15-L6	10" [254]	37.0" [940]

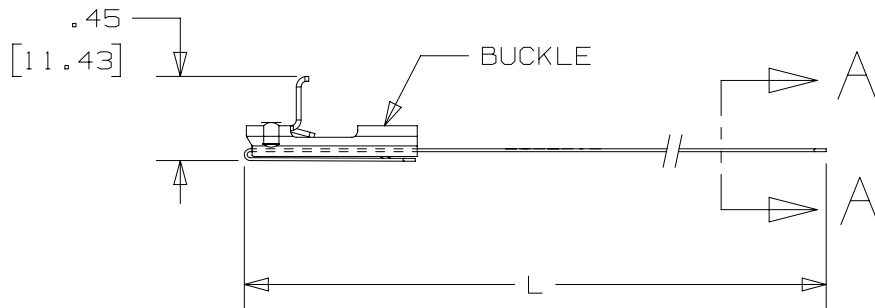
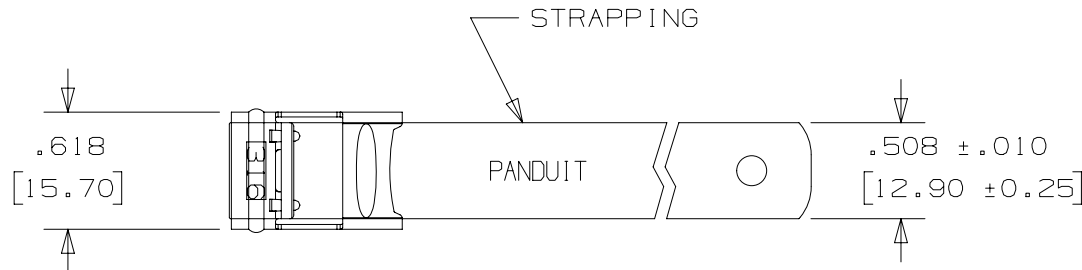

NOTES:

1. APPLICATION TOOLS: BT2HT.
2. ALL DIMENSIONS IN [] ARE mm.
3. BASE MATERIAL: 316 STAINLESS STEEL.
4. 100% COATED WITH BLACK NYLON.
5. COATING THICKNESS: .003/.005 [.076/.127] PER SIDE.
6. TOLERANCES (UNLESS OTHERWISE SPECIFIED):
 $\phi.X \pm .03 [.8]$
 $.XX \pm .02 [.5]$
 $.XXX \pm .007 [.18]$

REV	DATE	BY	CHK	APR	DESCRIPTION	ECN
03A	09-05-23	DPOI	JBN	MRWA	NOTE UPDATE. APPLICATION TOOL FROM BT2MS75, BT1HT TO BTH2T.	TC MIGRATION
02A	03-03-23	DPOI	JBN	MRWA	CHANGE NOTE 4. REMOVE "OR POLYESTER".	132977/00
01A	04-13-14	JAMB	MIM	RGRO	UPDATE DRAWING TO NEW GLOBAL PANDUIT TITLE BLOCK WITH PANDUIT LOGO.	SSECN01047
00A	10-03-14	JAMB	SKB	----	ORIG REV WAS 00, ORIG CAD FILE SPEC WAS S41168_00. NOTE APPLICATION TOOL BT1HT REPLACED BY BT2HT.	----
00	10-03-14	BRH	EJD	JJB	DRAWING RELEASED.	11159

PART NUMBER		COATED METAL STRAPPING .500 [12.7] WIDE		
CUSTOMER DRAWING				
ITEM REVISION NAME		N41168BS/03		
DATASET FILE NAME		N41168BS_DC/03A		
		THIRD ANGLE PROJECTION		
MATERIAL		SEE NOTES		
DRAWN BY		DATE	CHK	SCALE
BRH		10-03-2014	EJD	1:1
DRAWING NUMBER				SIZE
N41168BS_DC				A
SHEET 1 OF 1				

A-SIZE CUSTOMER